

Certus Model 450 Turntable Manual

21 - Dec - 2006



I. Bearing Assembly

The Teres bearing was designed to have a lot of viscous damping. This damping helps swamp the effects of stylus drag, resulting in better speed stability. For this reason relatively heavy oil (10 weight) is provided. With this oil the bearing will turn smoothly but there will be a lot of resistance. This is by design.

Please read this information carefully before assembling your bearing. The Teres bearing has been machined with very close tolerances. The radial clearance in the bearing is only 4 to 5 ten-thousandths. This tight tolerance results in superb stability reducing rocking to microscopic levels. However, with these tolerances it is imperative that the bearing is clean and that proper procedure is used for assembly. The objective is to have the bearing completely full of clean oil, including the recess in the top of the bearing housing. If air becomes trapped in the bearing it will not seat properly. The bearing must be assembled dry to avoid trapping air. The procedure:

1. Clean the bearing housing and spindle thoroughly. Wiping down the bearing surfaces with rubbing alcohol on paper towel works well.
2. Fill the recess in the bottom of the spindle with oil and press in the ball

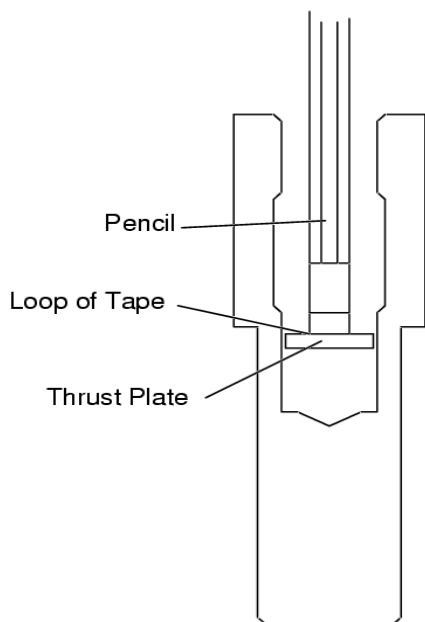

3. bearing. This displaces air in the recess and will hold the ball bearing in place. Be sure to completely wipe away any excess oil.
3. Place 3 to 4 drops of oil into the bottom of the bearing housing.
4. If not already installed place the brass thrust plate in the bottom of the bearing housing with the white Delrin button facing upward. The thrust plate needs to be held flat as it is lowered into the bearing. A simple method is to attach a small loop of tape to the end of a pencil. Then stick the thrust plate to the pencil and lower it in place. Be sure that the Delrin button is facing up!
5. Carefully dispense 5.0ml of oil into the bearing housing without getting any oil on the sides of the bearing.
6. Insert the spindle into the bearing. The spindle will stop about 1/2" before it is fully seated.
7. Install the platter on the spindle. The platter is very heavy and will require two people to install. Inflate the provided air jacks so that they are about 1" thick. Place the air jacks on both sides of the base under where the platter will go. Orient so that the tubing will not be under the plater. With two people carefully lower the platter so that it rests on the air jacks. Slowly let air out of both

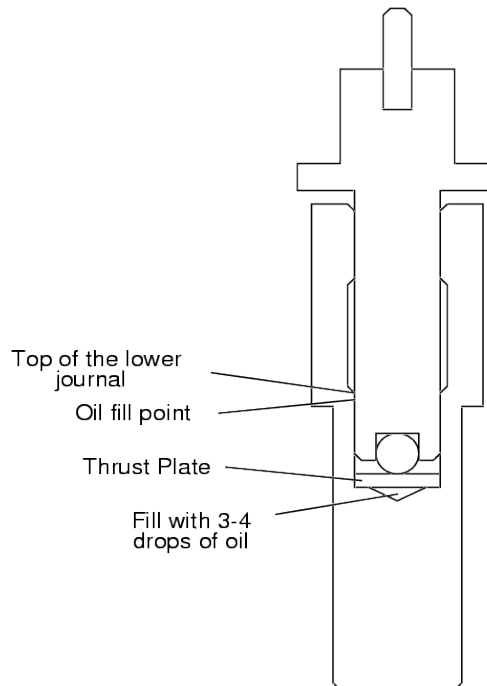

jacks to lower the platter onto the bearing spindle. As the platter is being lowered rotate the platter as required to align the platter mounting holes with the holes in the spindle. A small screwdriver may be inserted into the mounting holes to rotate the spindle for final alignment.

8. Install but do not tighten the 8, 10- 32 screws used to fix the platter to the bearing spindle.
9. Once the platter is in place wait for the spindle to displace the oil and fully seat. This will take roughly 30 minutes so be patient. When fully seated the gap between the platter and the base will be about 0.10" (slightly less than 1/8th inch). **WARNING**, do not spin the platter until the bearing has fully seated!
10. Once the platter has seated use the provided dial indicator to accurately center the platter onto the spindle as follows:
 - loosen all 8 of the platter mounting screws and then lightly tighten two screws on opposite sides.
 - Wrap the end of the dial indicator rod with scotch tape to avoid scratching the edge of the platter.
 - Setup the dial indicator and stand so that the rod of the dial indicator presses against the edge of the metal platter plate. The dial indicator shaft should point straight out from the edge of the platter.
 - Place the dial indicator so that the dial is deflected at least one half of a rotation.
 - Slowly rotate the platter and locate the point where there is maximum deflection of the needle. Also note the amount of deflection.
 - Use the provided rubber mallet to tap on the edge of platter (at the point of maximum deflection) to move the platter 1/2 of the amount of deflection noted before. You may need to hold the dial indicator base in place to keep it from being jarred during this operation. A series of small taps works best.
 - Repeat this process until there is less than 0.002 (two tick marks) of deflection as the platter is rotated. This is a tricky process and may take some time to master. Please be

patient.

- Once the platter is centered tighten two of the bolts and then recheck. Sometimes tightening the bolts will change the centering slightly. If this happens loosen the bolts just enough that the platter can be adjusted and repeat the centering process.
 - Tighten the remaining 6 bolts.
11. Thread the chrome record centering pin into the top of the platter. Tighten the centering pin with pliers will keep it from backing out while using the clamp.
 12. Connect the cable from the base to the motor controller.

II. Armboard Setup

The model 450 armboard is secured by a 3/8" bolt extending from the armboard to the bottom of the 450 base. A 3/16" allen wrench is required to adjust and tighten the armboard.

1. Start by using the 3/16" allen wrench to set the armboard tension so that the armboard is steady but loose enough that it can be adjusted by hand. The allen wrench is inserted into the center of the armboard bolt from underneath the turntable base.
2. Install the tonearm and cartridge and adjust the overhang by rotating the armboard.
3. After the overhang adjustment is complete tighten the armboard bolt. Use the 3/16" allen wrench to tighten the armboard bolt. The proper amount of torque is roughly what can reasonably be exerted using a small allen wrench.

III. Operation

The Certus controller has a single control switch with 5 positions, off and 0, 33, 45 and 78 RPM.

Power on the controller by rotation the switch from off to the 0 RPM position. When the controller is first powered up it goes through a 5 second sequence that aligns the motor magnets. The red and yellow LEDs light during this process and the platter movement will be erratic.

To start the turntable simply rotate the switch to the desired speed. The red LED will light during the spin up process. The green LED lights when the desired speed has been reached but the speed is not fully stabilized until the red LED shuts off. To stop rotate the switch to the 0 RPM position. It's best to not power down the controller until the listening session is over. Do not spin the platter by hand.

The Certus controller has a sleep timer feature that will shut off the controller after 42 minutes of uninterrupted play. The yellow LED flashes to provide a two minute shutoff warning. When the sleep timer expires the motor will shut off and the yellow LED will flash slowly. Reset the sleep timer by turning the controller switch to the off position. The sleep timer may be disabled if desired.

IV. Reflex Clamp

A reflex clamp is provided with the model 450 and it's use is optional. Unlike other Teres models clamping may or may not produce the best results. To use the reflex clamp place the black Delrin washer packaged with the record clamp over the record centering pin. The Delrin washer must be placed directly on the platter and under the record. Place the record over the spindle and then thread on the clamp. **Be sure to remove the Delrin washer if the clamp is not used.**

Only a small amount of clamping pressure is needed. A simple method for finding the ideal pressure is to tap on the edge of the record while clamping. Taping the edge of the record will make a slight clicking sound as the record edge contacts the platter.

Tighten the clamp to the point where the edge of the record has the best contact as indicated by the least amount of "clicking". The pressure is not critical and after a little use the process will become automatic.

V. Controller Options

The Certus motor controller has a small number of options that may be adjusted via internal switches mounted on the front PCB. The top cover must be removed for access to the switches.

S1 (8 position DIP switch)

Sw1- 3: Pitch adjust
Sw4: Unused
Sw5: Sleep timer, on = enabled
Sw6: Must be off
Sw7- 8 Must be off

Pitch Adjust Settings

Sw1	Sw2	Sw3	Pitch @ 33- 1/3
On	On	On	+2.80%
Off	On	On	+2.08%
On	Off	On	+1.37%
Off	Off	On	+0.68%
On	On	Off	- 0.011% (default)
Off	On	Off	- 0.69%
On	Off	Off	- 1.36%
Off	Off	Off	- 2.02%

S2 (8 position rotary switch)

S2 may be used to fine tune motor torque for desired sound quality. The default setting has been carefully optimized and will likely be the preference for most listeners.

S2	Torque Percent @ 33- 1/3 RPM
0	58.6%
1	63.5%
2	68.4%
3	73.2%
4	78.1% (default)
5	83.0%
6	87.9%
7	92.8%

VI. Technical Specifications

Dimensions:

- Model 450: 16.5 x 12.75" x 11.25"
- Motor Controller: 13" x 13.5" 5.5"

Weight:

- Model 450: 150 Lbs. (excluding controller)
- Platter: 65+ Lbs.
- Motor Controller: 18 Lbs.

Drive System:

- Low cogging multi-phase permanent magnet synchronous (patent pending)
- Magnetic damping via eddy current brake (patent pending)
- High torque capability (563 oz/inch)
- High resolution digital drive signal synthesis
- Speeds Supported: 33- 1/3, 45 and 78
- Speed Accuracy
 - 33- 1/3 RPM: - 0.011% +- 0.003%
 - 45 RPM: - 0.006% +- 0.003%
 - 78 RPM: - 0.160% +- 0.003%
- Pitch adjustment available via internal DIP switch, 8 steps at 0.46% per step (33- 1/3 RPM) and 0.63% (45 RPM).
- Optional sleep timer (shuts off after 42 minutes of uninterrupted operation)

Bearing Assembly:

- Upward facing, platter imbedded
- Massive 1" diameter stainless steel spindle
- High center of gravity (thrust surface is above lower platter surface)
- Thrust surface: 1/2" precision ball bearing and a replacable Delrin/brass thrust plate.
- High precision ground and polished bearing surfaces with precise 4- 5 ten thousandths radial clearance.
- Oil bath design with viscous damping and superior lubrication

Power Requirements:

- 115- 125vac, 0.68 Amps, 82 watts
- 230- 250vac, 0.34 Amps, 82 watts
- Fuse:
 - 120vac - 1.5 amp slow blow
 - 240vac - 1 amp slow blow